

# ChemSkid

Chemical dosing skid

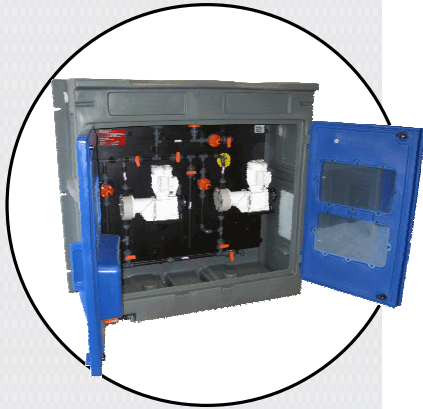

- Compact ready-to-use unit
- Standardized construction
- Reduced integration costs
- Maximum operator safety

## Applications:

Dosing chemical reagents (including ferric chloride, sodium hydroxide and various acids) in industrial processes such as water treatment, chemicals, paper-making and metallurgy.

## Operation:

The ChemSkid:

- Injects chemicals in response to an external signal (e.g. pH control),
- Provides continuous service (with standby pump),
- Ensures the safety of equipment and personnel.

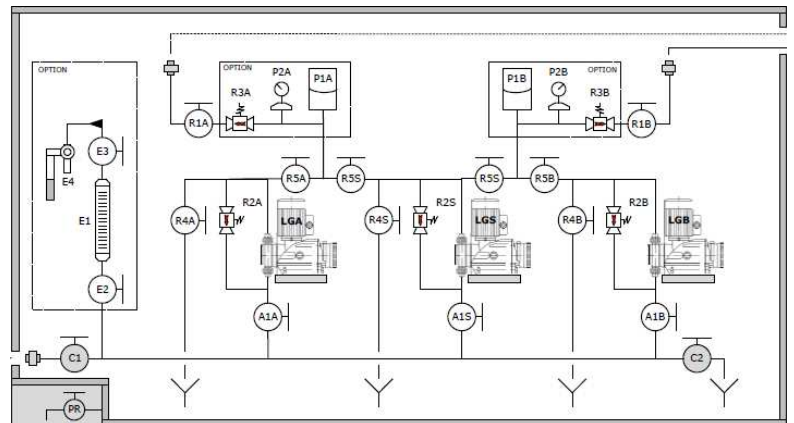

## Components:

Unit securely installed in a cabinet, with:

- One or two diaphragm dosing pumps (with or without standby pump),
- Integrated monitoring and safety systems,
- Wide range of options, including pressure switch, priming pump, calibration pot, pressure gauge, etc.

## Avantages:

- Easy to integrate with existing systems,
- Continuity of service,
- Safe operation.

